

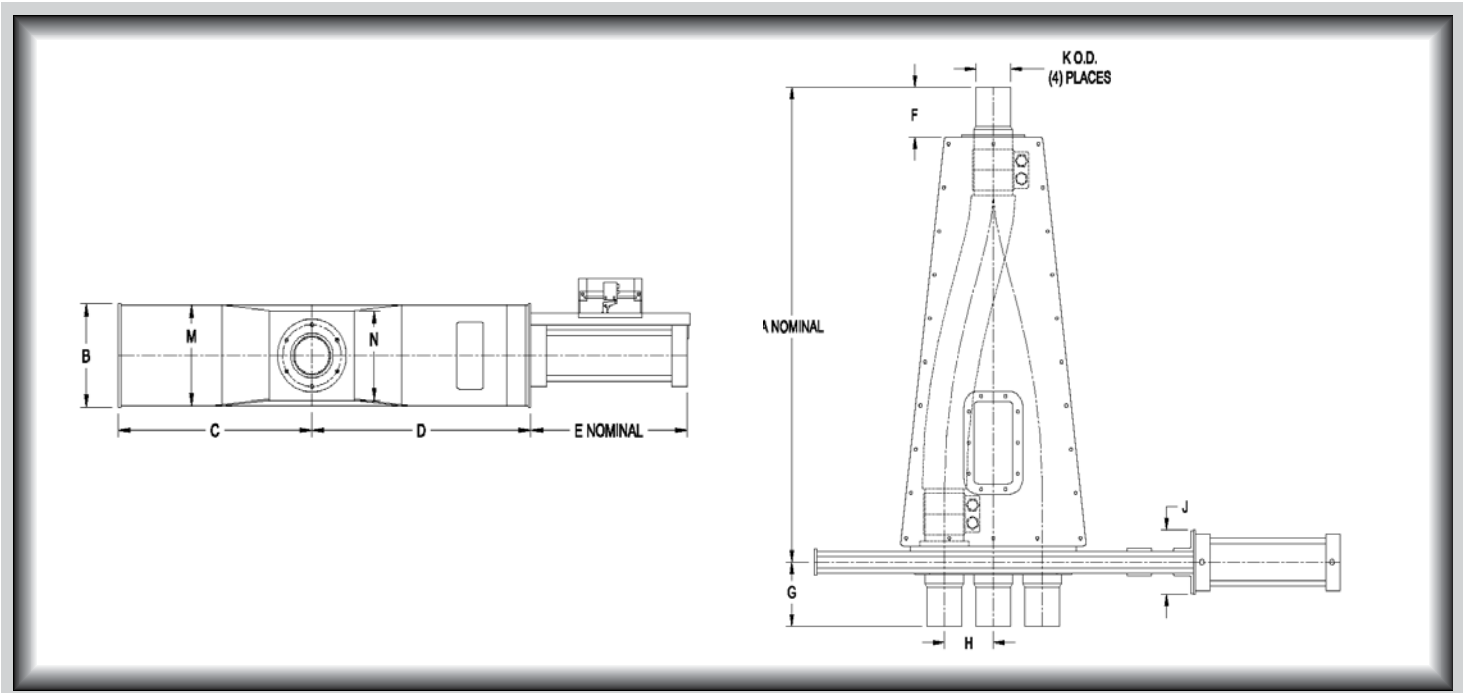

VORTEX® 3-WAY FLEX TUBE DIVERTER™ DIMENSIONAL INFORMATION



MODEL	TUBE SIZE	A	B	C	D	E	F	G	H	J	K	M	N	WT (kg)
T2-3(XX)Y	51	772	184	273	330	248	76	105	64	127	51	184	127	45
T2.5-3(XX)Y	64	921	225	333	403	365	76	133	89	159	64	219	168	59
T3-3(XX)Y	76	889	225	333	403	365	73	108	89	159	76	225	168	59
T4-3(XX)Y	102	1118	229	467	527	375	67	105	127	159	102	229	191	73
T5-3(XX)Y	127	1229	270	537	625	451	92	133	152	184	127	270	232	91
T6-3(XX)Y	152	1829	286	641	705	502	98	130	178	171	152	286	254	118
T8-3(XX)Y	203	2203	337	927	972	657	98	235	254	391	203	356	333	145

MODEL	PIPE SIZE	A	B	C	D	E	F	G	H	J	K	L	M	N	WT (kg)
T2-3(XX)Y-P*	51	921	225	333	403	365	76	133	89	159	60	76	219	168	59
T2.5-3(XX)Y-P*	64	921	225	333	403	365	76	133	89	159	73	76	219	168	59
T3-3(XX)Y-P*	76	1178	235	467	527	375	102	156	127	140	89	102	229	178	73
T4-3(XX)Y-P*	102	1257	270	562	625	451	102	162	152	184	114	127	260	232	91
T5-3(XX)Y-P*	127	1549	286	641	705	502	102	156	178	165	141	152	279	254	118
T6-3(XX)Y-P*	152	1873	286	641	705	502	146	**	184	171	168	152	279	254	125
T8-3(XX)Y-P*	203	2305	337	927	972	657	152	241	254	391	219	203	356	333	227

All dimensions are in mm, Information subject to change without notice.

(XX) Material of construction, aluminum (AL), carbon steel (CS), or stainless steel (SS).

*Select pipe schedule 10 or 40, note flex tube is O.D. tube.

** - For T6-3(XX)Y-P* the (G) dimension for outside ports is 187mm, (G) dimension for center port is 378mm to allow for Morris couplings.